

Robot Cart

(am-5678)

Assembly Guide



Revision #	Date	Author	Purpose
0	11/19/2025	E. Scime	Original Document
1	4/6/2026	N. Massouda	Updated Gussets, Hardware, and Tools

P. Yeung	4/6/2026
_____ Reviewer Name	_____ Date Reviewed



Need help with an AndyMark product? Contact us at support@andymark.com.









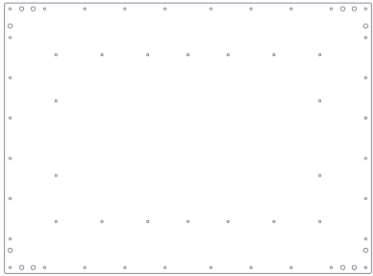

Parts & Tools

Recommended Tools List





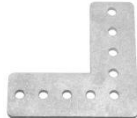

Component	Part #	QTY	Photo
5/32 Ball End Hex Driver	am-2751	1	
3/8 Combination Wrench	am-4961	1	
1/8 Ball End Hex Driver	am-2750	1	
1/4-20 Clearance (0.266") Drill Bit	am-5817	1	
Drill	N/A	1	
Hammer	N/A	1	



Parts List

Component	Part #	QTY	Photo
Polycarbonate Belly Pan	am-5678_pan	1	
Polycarbonate Driver Station Tray	am-5678_tray	1	
Polycarbonate Battery Tray	am-5677	2	
1" x 1" Pre-Drilled Square Tube, 47"	am-5177 OR am-5178	10	
Aluminum Tube, Round, 7/8 OD x .065, 47"	am-5354-47	1	
Inside Corner Gusset	am-5653	6	
Tee Gusset	am-4158 OR am-4158a	12	
90 Degree Gusset	am-3860 OR am-3860a	12	
Sharp Corner 90 Degree Gussets	am-3860a	2	
4 in. Caster Assembly with Brake	am-4989	4	



Caplug, Square, Flexible Vinyl, 1"x1"x1", Black	am-4501	4	
Screw, BHCS, 1/4-20 x 2000	am-1655	4	
Nut, Tube Connector, 1/4-20 threads for 7/8" OD tube	am-1727	4	
Ring Pin, 1 5/16"	am-2579	2	
AM Lanyard Key Chain, Red	am-5679	2	
2" Wide Loop Adhesive Back	ip-2802a_loop_2	4	
0.260 in. ID 0.750 in. OD 1.000 in. Long Nylon Spacer	am-1449	4	
Screw, SHCS, 10-32 x 1500, Zinc	am-1014	72	
Screw, SHCS, 10-32 x 1750, Zinc	am-1048	18	
Screw, SHCS, 10-32 x 1375, Zinc	am-1154	20	
Screw, SHCS, 10-32 x 750, Zinc	am-1047	2	
Nut, Nylock Jam, 10-32	am-1063	130	
Screw, FHCS, 10-32 x 1500	am-1756	16	
Washer, #10 Steel	am-1026	25	

Assembly

Step 1

Cut the provided [10] 1x1 box tube extrusions (am-5177 or am-5178) into 16 total parts (plus scrap) as described in the following table. Make sure to always cut parts such that one end always has a factory-cut edge for best alignment during assembly. Additionally, cut [2] 21.5" lengths of 7/8" OD aluminum tube (am-5354).

Stick #	Length of Cut #1	Length of Cut #2	Extra Remaining
1	39"		8"
2	39"		8"
3	31"		16"
4	31"	11.5"	4.5"
5	31"	15.5"	0.5"
6	31"	15.5"	0.5"
7	23.5"		23.5"
8	21.5"	21.5"	4"
9	21.5"	21.5"	4"
10	19"	19"	9"

Step 2

Using [2] 31" long pieces of 1x1, [1] 21.5" long piece of 1x1, and [1] 23.5" long piece of 1x1, create a frame above the base plate (am-5678_pan) and secure it in place with [16] 1.5" long 10-32 socket head cap screws (am-1014) and [16] 10-32 nylock jam nuts (am-1063) ONLY in the locations shown.

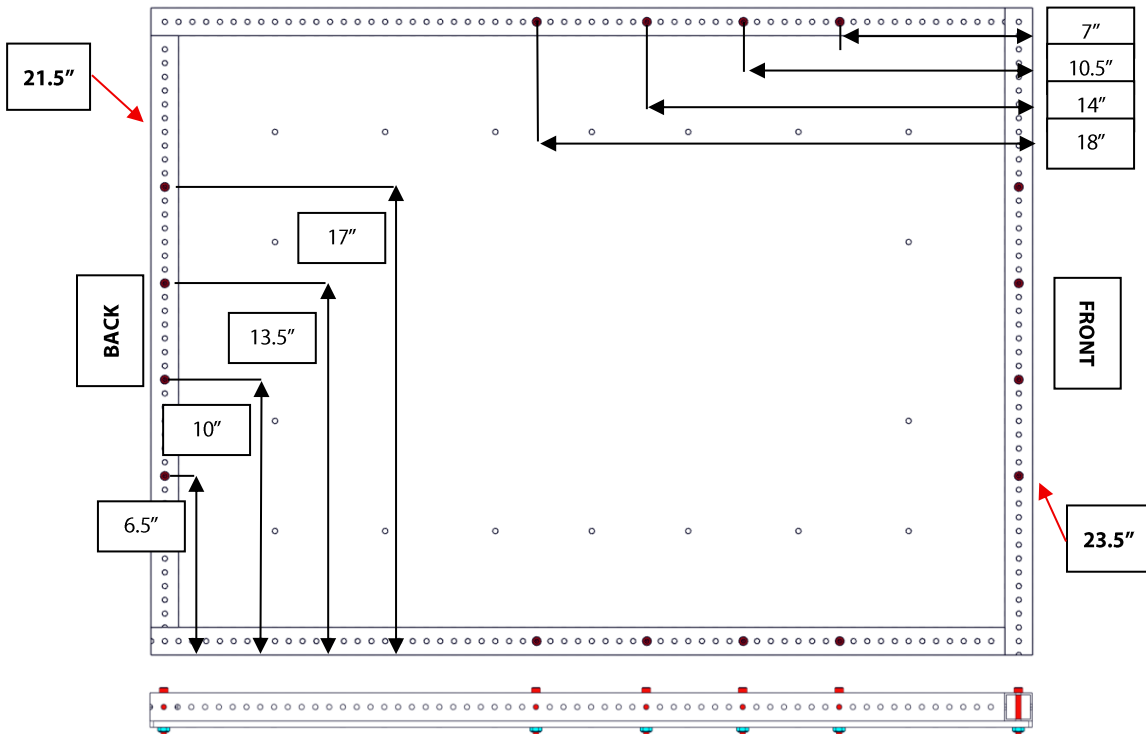

Step 3

Flip the assembly upside down. At the **FRONT** of the cart, attach [2] caster wheels (am-4989) and [2] Sharp Corner 90 Degree Gussets (am-3860a) using [6] 1.75" long 10-32 socket head cap screws (am-1048), [6] 1.375" long 10-32 socket head cap screws (am-1154), [6] #10 washers (am-1026), and [12] 10-32 nylock jam nuts (am-1063).

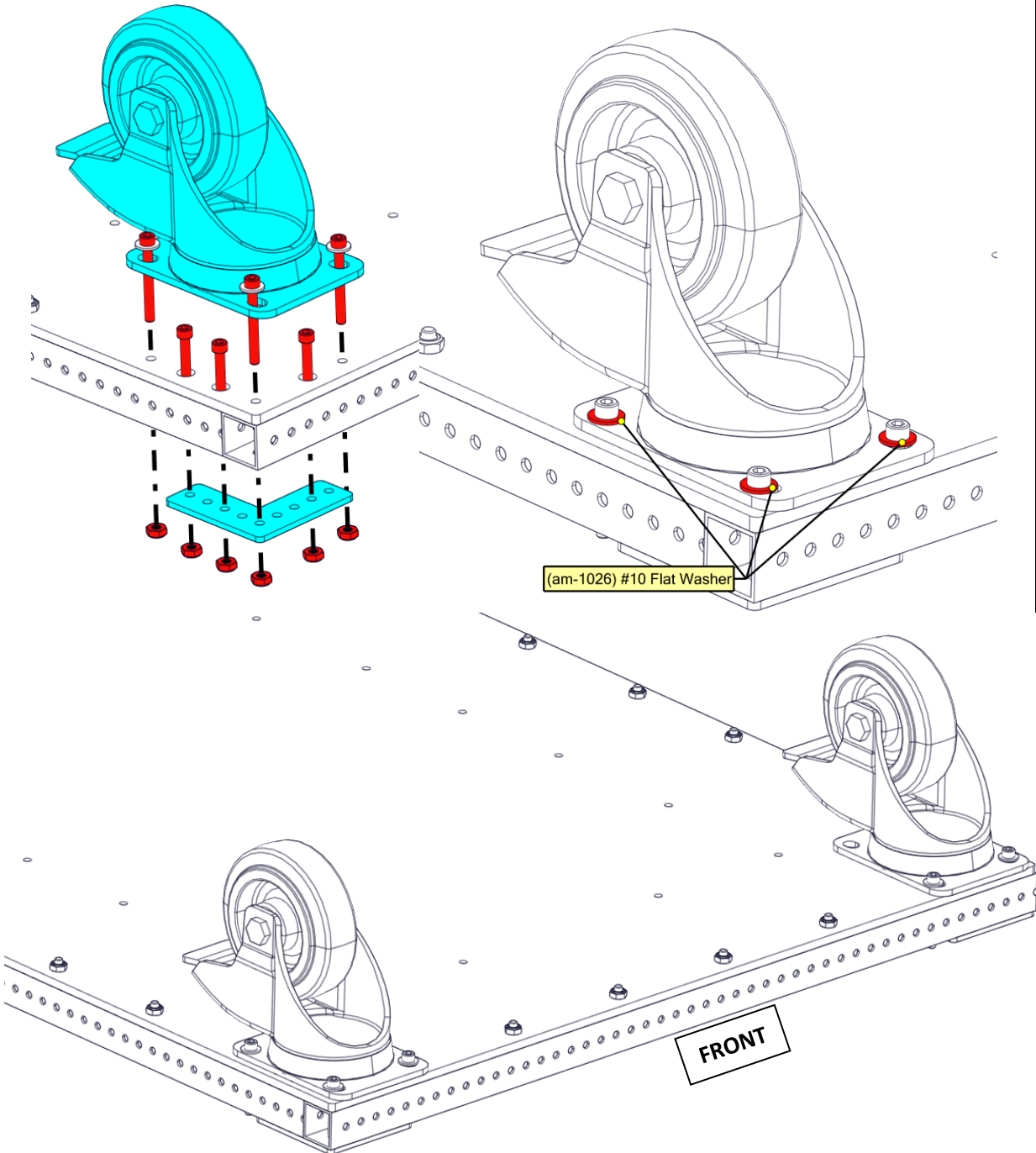

Step 4

At the **BACK** of the cart, attach [2] caster wheels (am-4989) and [2] Inside Corner Gussets (am-5563) using [4] 1.75" long 10-32 socket head cap screws (am-1048), [6] #10 washers (am-1026), [2] 1.375" long 10-32 socket head cap screws (am-1154), [2] 0.75" long 10-32 socket head cap screws (am-1047), and [8] 10-32 nylock jam nuts (am-1063).

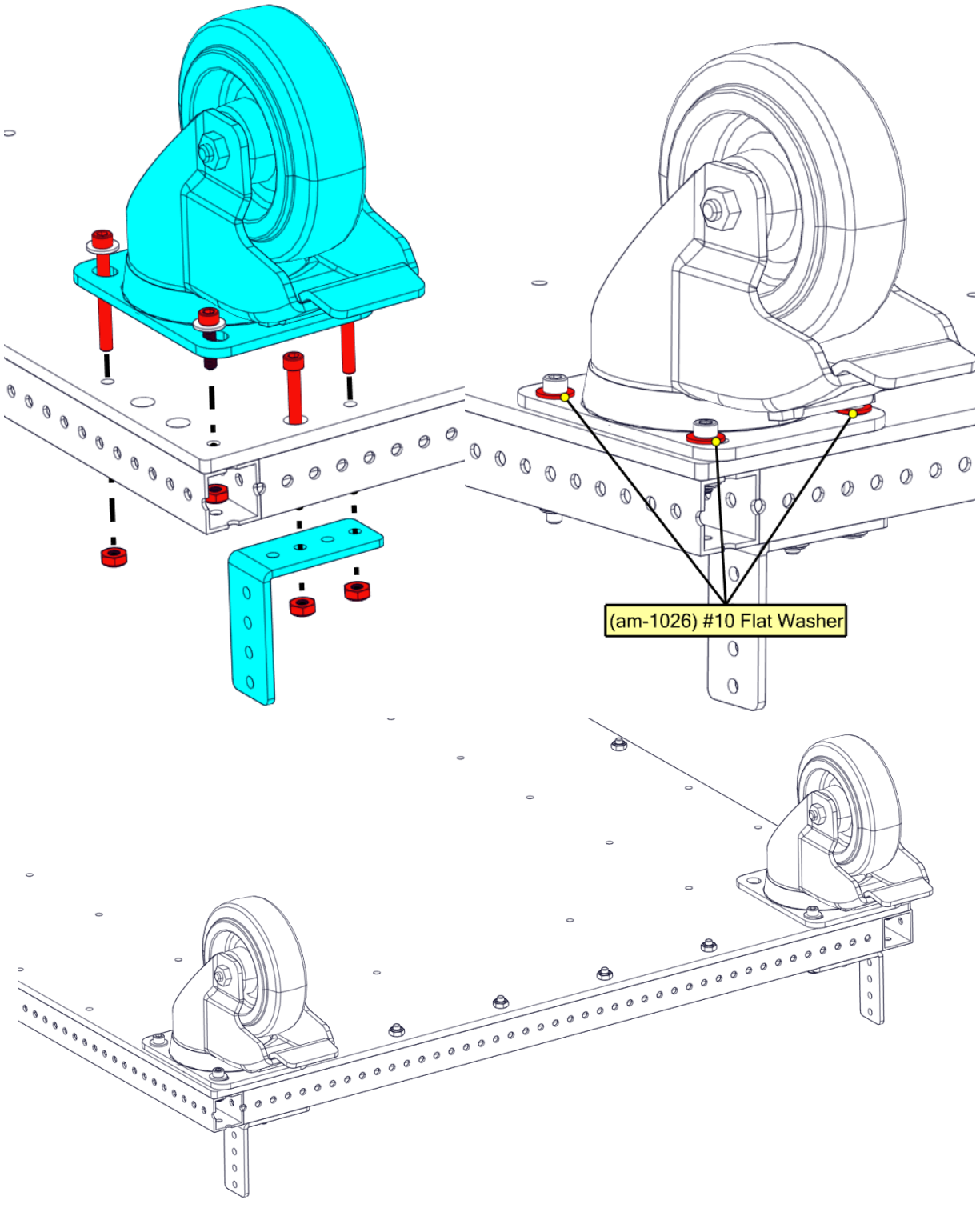

Step 5

Attach [2] battery mounts (am-5677) using [8] 1.75" long 10-32 socket head cap screws (am-1048), [8] 10-32 nylock thin nuts (am-1063), and [2] 1" long spacers (am-1449). These can be placed anywhere along the perimeter of the cart to your preference.

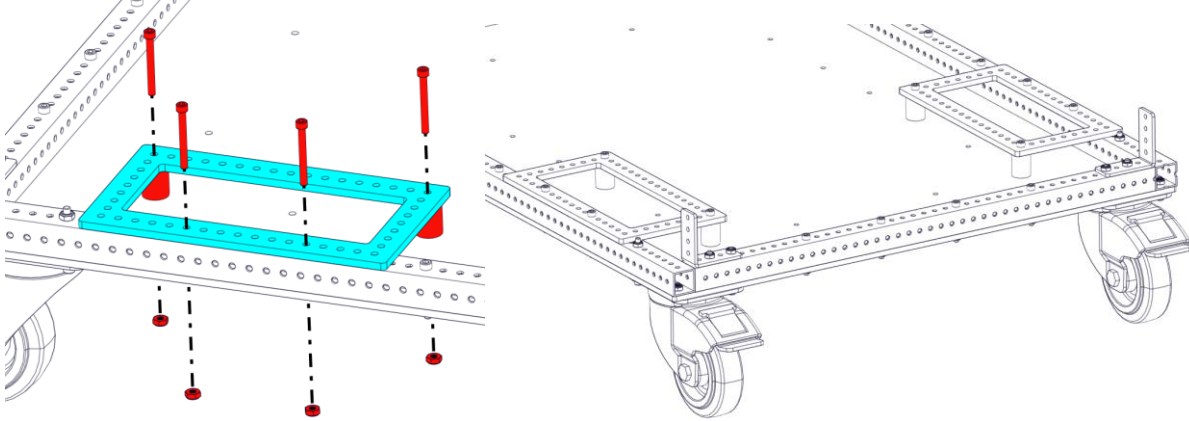

Step 6

Attach [2] 39" long 1x1 tubes to the **BACK** of the robot cart using [2] 90 Degree Gussets (am-3860 or am-3860a), [4] 1.375" long 10-32 socket head cap screws (am-1154), [4] 1.5" long 10-32 socket head cap screws (am-1014) and [8] 10-32 nylock jam nuts (am-1063).

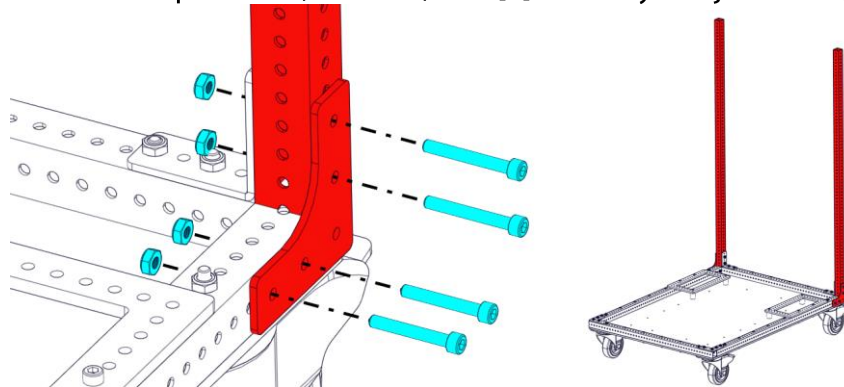

Step 7

Attach [2] 15.5" long 1x1 tubes to the **FRONT** of the robot cart using [4] T-Gussets (am-4158 or am-4158a), [10] 1.5" long 10-32 socket head cap screws (am-1014) and [10] 10-32 nylock jam nuts (am-1063).

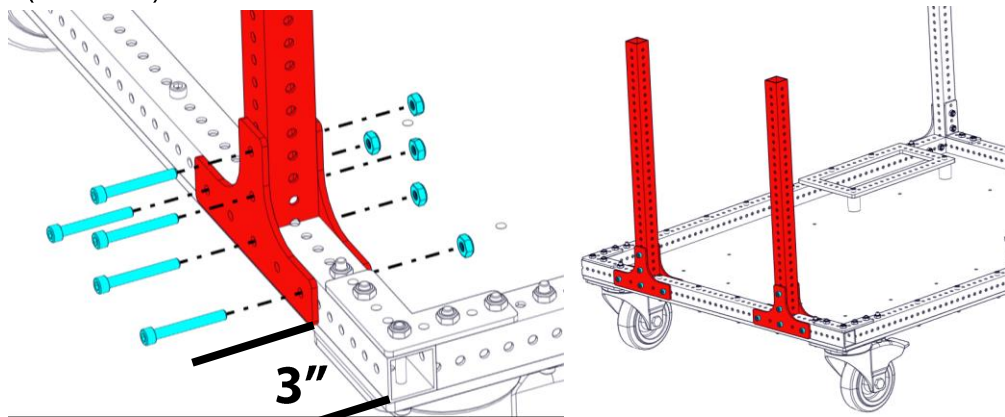

Step 8

At the **FRONT** of the cart, attach [1] 11.5" 1x1 tube to both of the 15.5" tubes using [2] Inside Corner Gussets (am-5653), [2] 90 Degree Gussets (am-3860 or am-3860a), [4] 1.5" long 10-32 socket head cap screws (am-1014), [4] 1.375" long 10-32 socket head cap screws (am-1154) and [8] 10-32 nylock jam nuts (am-1063).

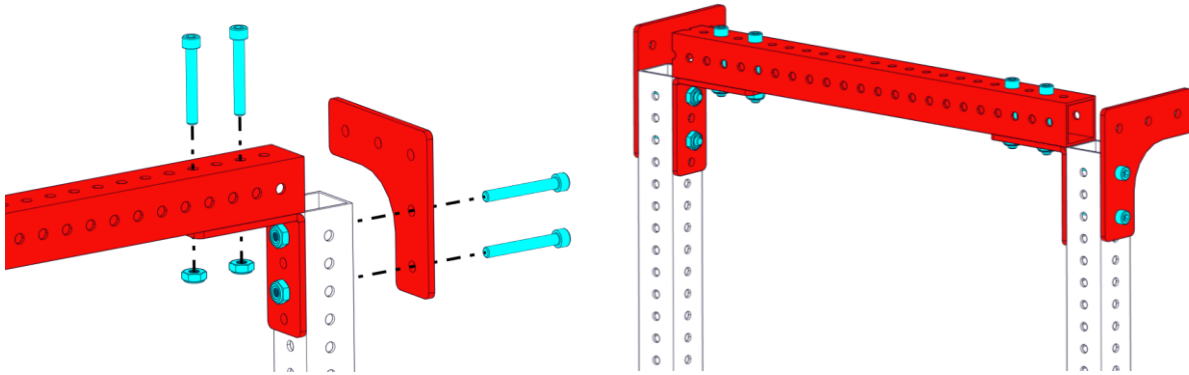

Step 9

At the **FRONT** of the cart, attach [2] 31" 1x1 tube to the 15.5" tubes and 11.5" tube mounted there using [2] Inside Corner Gussets (am-5653), [4] 1.5" long 10-32 socket head cap screws (am-1014), [4] 1.375" long 10-32 socket head cap screws (am-1154) and [8] 10-32 nylock jam nuts (am-1063).

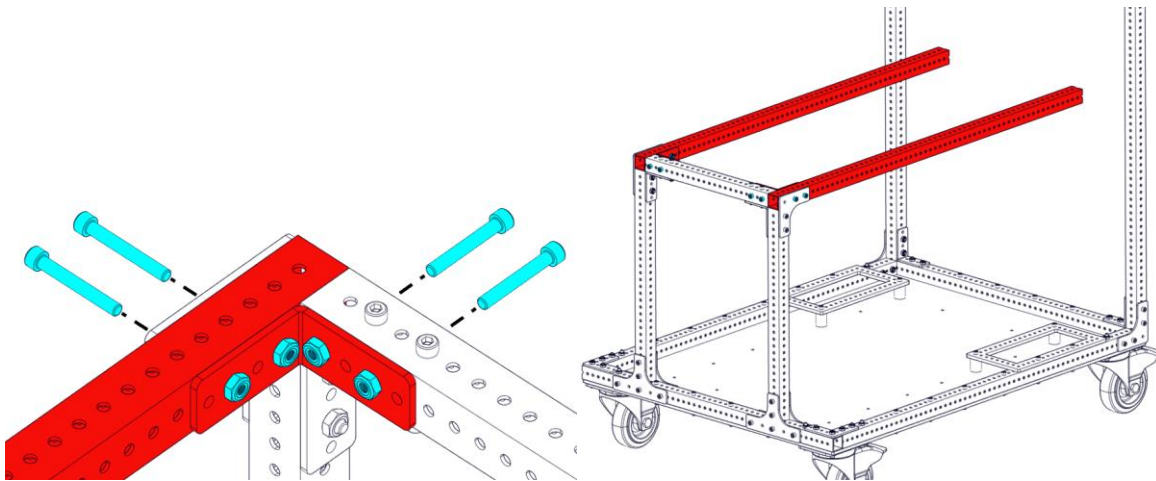

Step 10

At the **BACK** of the cart, attach [1] 21.5" 1x1 tube to the 39" tubes mounted there using [8] T-gussets (am-4158 or am-4158a), [28] 1.5" long 10-32 socket head cap screws (am-1014), and [28] 10-32 nylock jam nuts (am-1063).

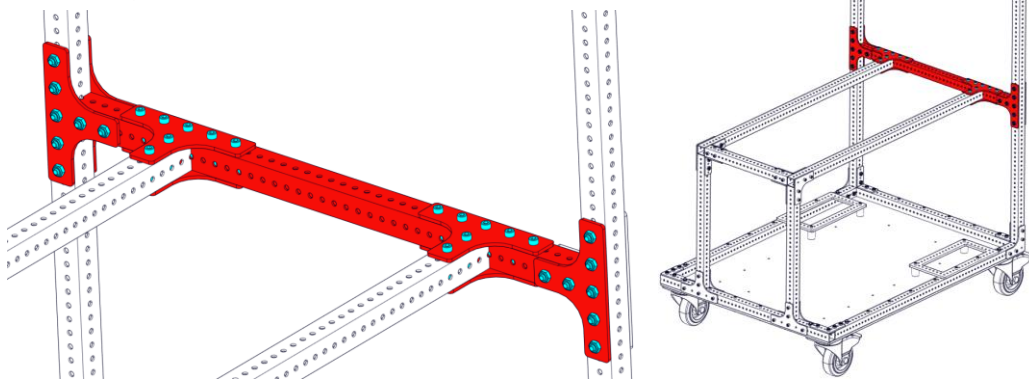

Step 11

Into each end of each of the 7/8" tubes cut in Step 1, insert a Tube Connector Nut (am-1727) (4 total). This can be done by installing a 2" 1/4-20 button head cap screw (am-1655) in the nut and hammering it into the tube until it is 1/4" past the end of the tube, then removing it.

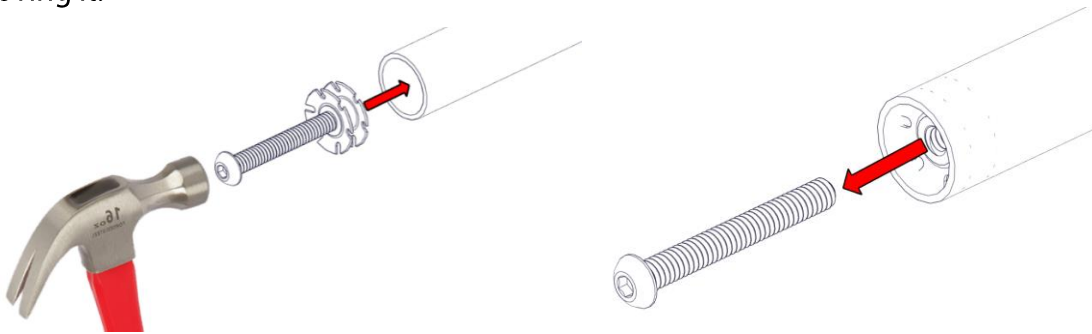

Step 12

Install [2] 21.5" long 1x1 tubes and [2] 19" long 1x1 tubes onto [1] driver station tray (am-5678_tray) using [4] 90 Degree Gussets (am-3860 or am-3860a), [16] 1.5" long 10-32 flat head cap screws (am-1756), and [16] 10-32 nylock jam nuts (am-1063).

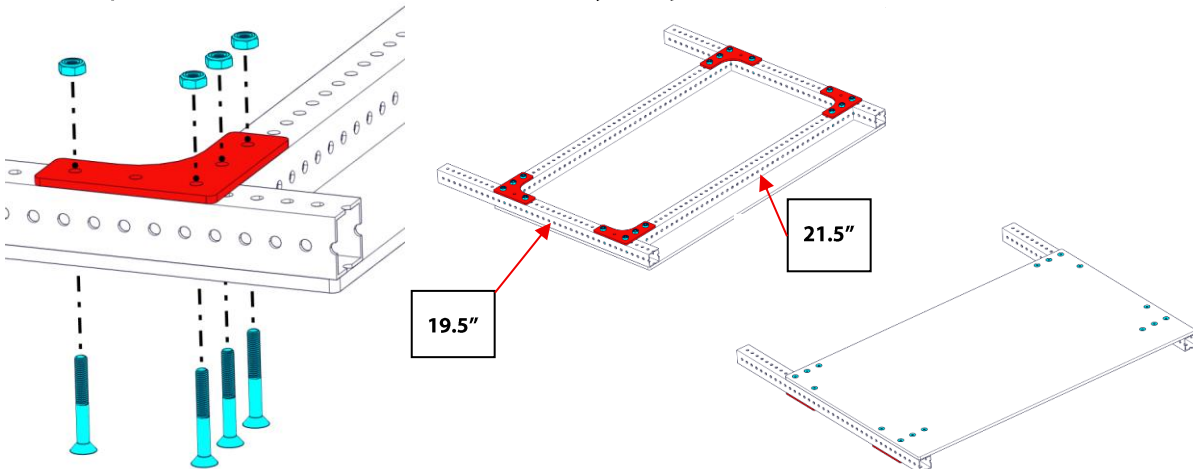

Step 13

Drill out the two holes shown with a 0.266" diameter drill bit.

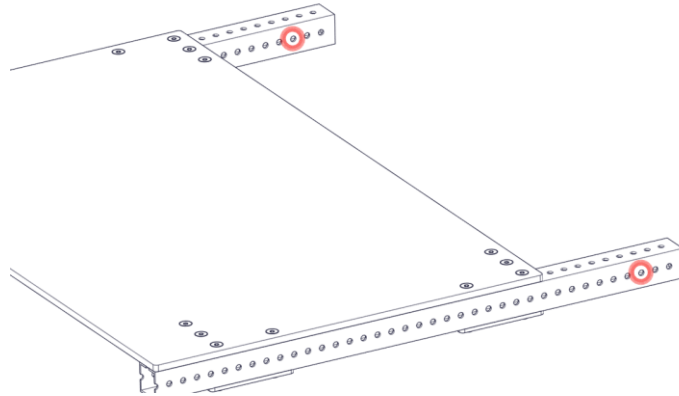

Step 14

Install [1] 7/8" tube using [2] 2" 1/4-20 button head cap screws (am-1655) through the holes drilled in Step 13.

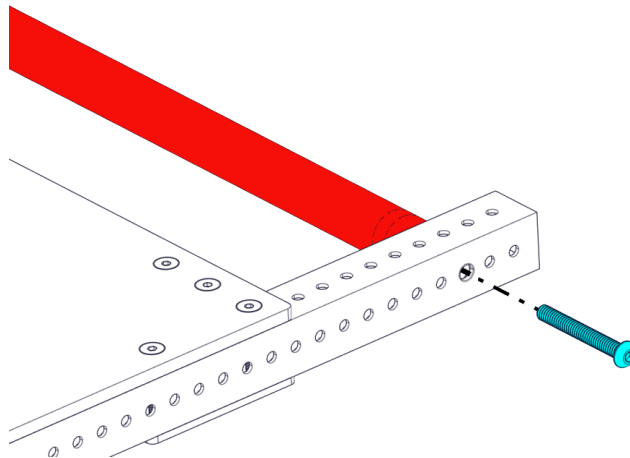

Step 15

Create the hinges for the driver station tray and install it using [4] 90 Degree Gussets (am-3860 or am-3860a), [12] #10 washers (am-1026), [6] 1.5" long 10-32 socket head cap screws (am-1014), and [6] 10-32 nylock nuts (am-1063). Pin the hinges in place using [2] 1-5/16" long pull pins (am-2579).

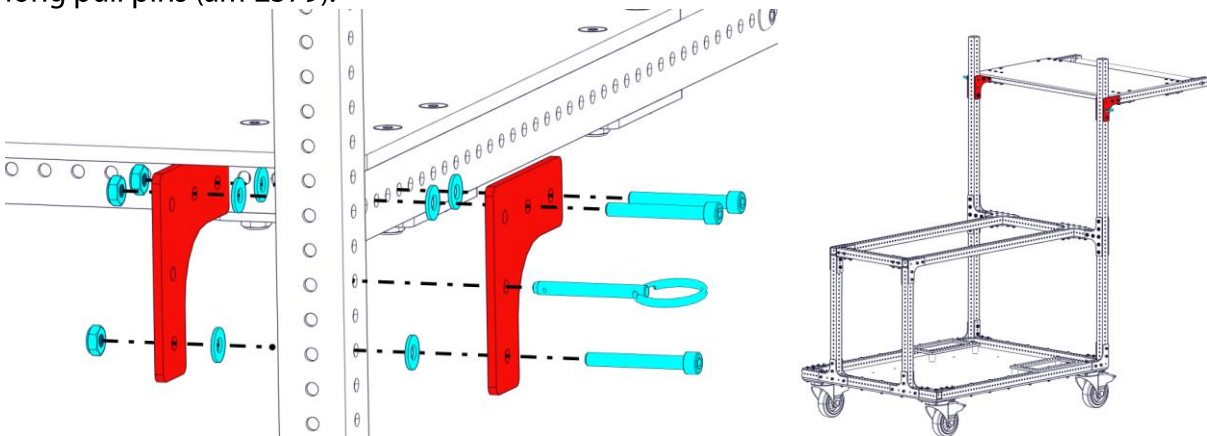

Step 16

Drill out the two holes shown with a 0.266" diameter drill bit.

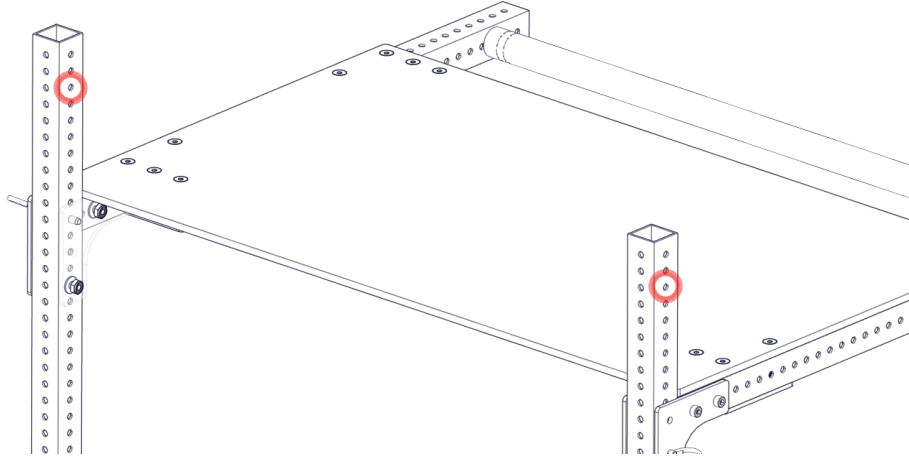

Step 17

Install [1] 7/8" tube using [2] 2" 1/4-20 button head cap screws (am-1655) through the holes drilled in Step 16.

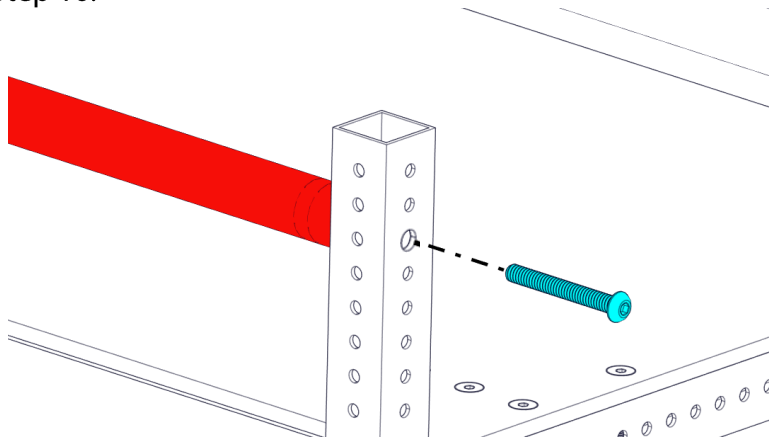

Step 18

Slide on [4] square vinyl caps (am-4501) in the locations shown.

